

ZONING DATA TABLE ZONING DISTRICT I-1			
ITEM	REQUIRED/ ALLOWED	EXISTING	PROPOSED
MINIMUM LOT AREA WITH PUBLIC WATER	40,000 S.F.	134,812 S.F.	134,812 S.F.
MINIMUM FRONTAGE	50'	378.72'	378.72'
SETBACKS			
FROM STREETLINE	50'	84.3'	84.3'
FROM REAR PROPERTY LINE	20'	>20'	>20'
FROM OTHER PROPERTY LINE	20'	(N) 21.9'/(S) 50.8'	(N) 21.9'/(S) 50.8'
COVERAGE			
BUILDING/STRUCTURE COVERAGE	40%	20.5%	21.2%
GROSS FLOOR AREA	80%	27,667 SF	28,612 SF
		29,946 SF*	29,946 SF*
MAXIMUM BLDG. HEIGHT	50'	<50'	<50'

* PER TOWN OF OLD SAYBROOK VISION APPRAISAL WEBSITE

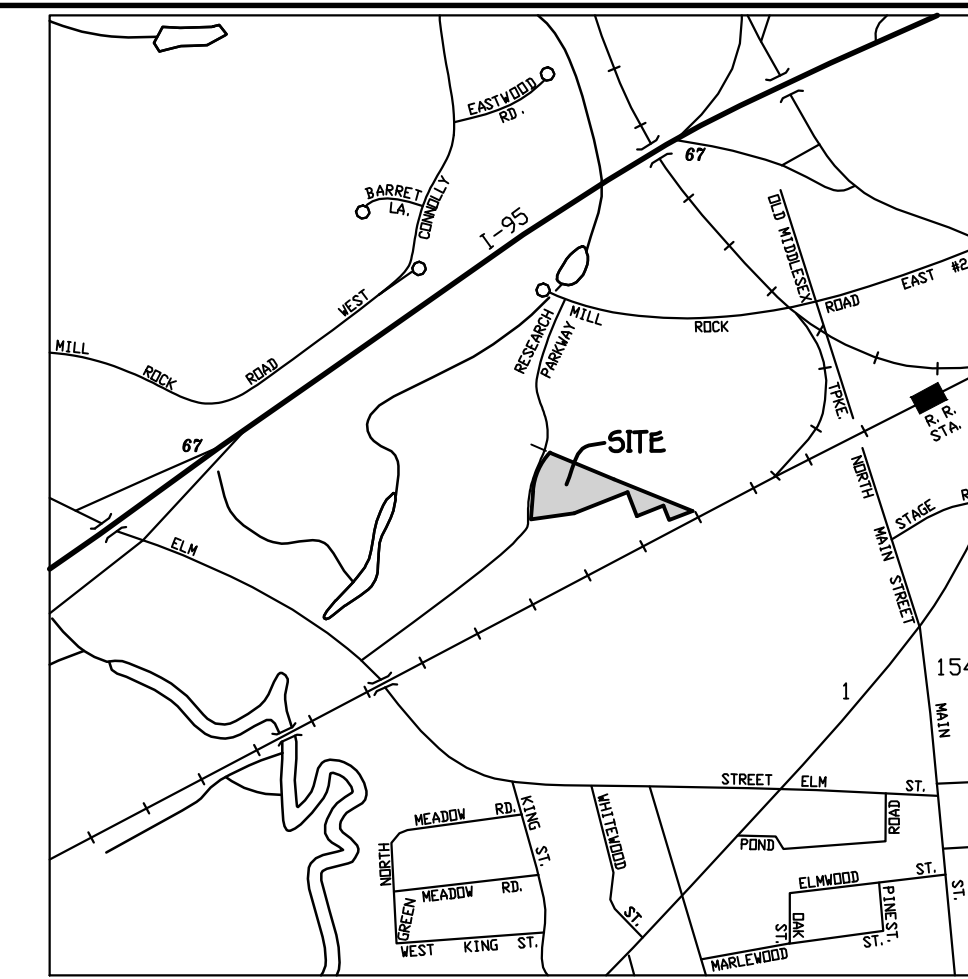

LOCATION MAP
SCALE: 1"=1000'

PARKING CALCULATIONS
31,024 SF GROSS FLOOR AREA (PROVIDED BY TENANT)
MANUFACTURING (17,744 SF) 17,744 / 800 SF = 23 SPACES
STORAGE (6,440 SF) 6,440 / 1,200 SF = 6 SPACES
OFFICE SPACE (6,840 SF) 6,840 / 200 SF = 33 SPACES
TOTAL SPACES REQUIRED = 39
TOTAL SPACES AVAILABLE (INCLUDING HANDICAP) = 56

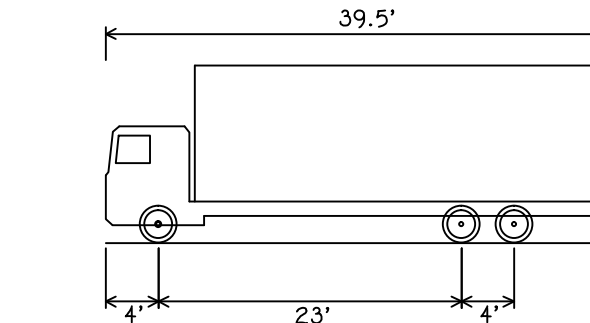

ASHTO - SU-40 TRUCK DETAIL
SCALE: N.T.S.

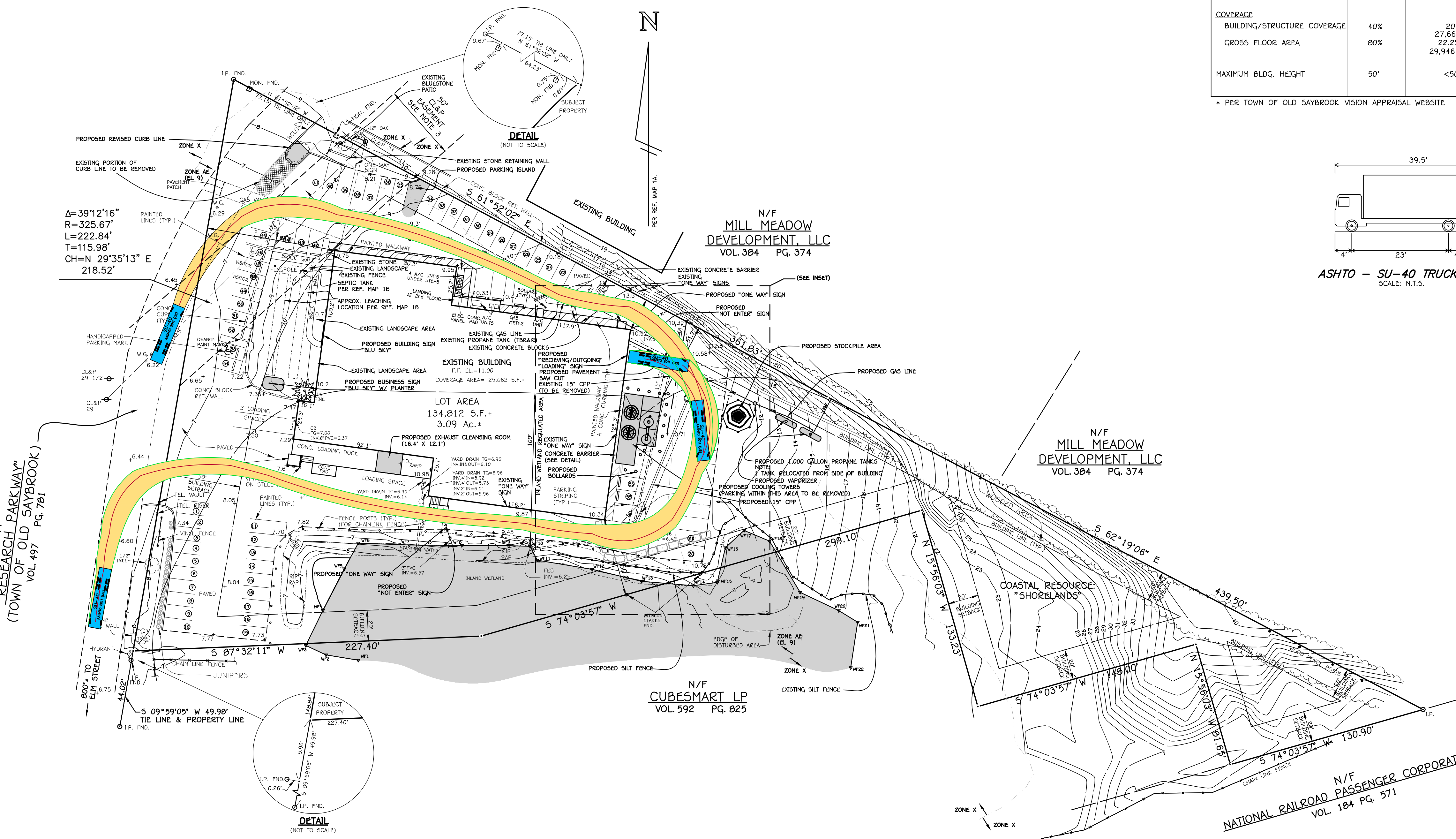

$\Delta=39'12'16''$
 $R=325.67'$
 $L=222.84'$
 $T=115.98'$
 $CH=N 29'35'13'' E$
 $218.52'$

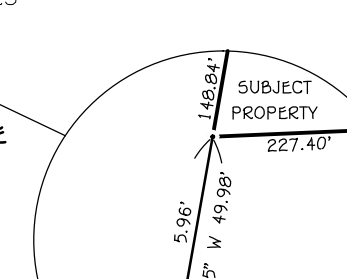

DETAIL
(NOT TO SCALE)

- LEGEND**
- UTILITY POLE
 - CONCRETE MONUMENT
 - FOUND
 - IRON PIPE
 - DRILL HOLE
 - EXISTING CONTOURS
 - EXISTING SPOT ELEVATION
 - FIRE HYDRANT
 - EDGE OF WETLAND/FLAG NUMBER
 - WATER GATE
 - CATCH BASIN
 - CORRUGATED PLASTIC PIPE
 - FLARED END SECTION
 - INVERT
 - TO BE REMOVED AND RELOCATED
 - TOP OF GRADE
 - EXISTING PARKING SPACE COUNT

I HAVE REVIEWED THE WETLANDS BOUNDARIES AS SHOWN ON THIS PLAN AND AM OF THE OPINION THAT THEY REPRESENT THE SOIL BOUNDARIES MARKED BY ME IN THE FIELD.

Richard Snarski
RICHARD SNARSKI, CERTIFIED SOIL SCIENTIST, #1975

DATE 03-13-2024

BOUNDARY LINES OF ADJOINING PROPERTIES ARE SHOWN FOR GENERAL INFORMATION. PURPOSES ONLY AND ARE NOT TO BE CONSTRUED AS BEING ACCURATELY LOCATED OR DEPICTED.

©2024 - ANGUS McDONALD / GARY SHARPE & ASSOCIATES, INC.

THESE DRAWINGS ARE THE PROPERTY OF ANGUS McDONALD/GARY SHARPE & ASSOCIATES, INC. AND HAVE BEEN SPECIFICALLY PREPARED FOR THE OWNER OF THIS PROJECT OR PROPERTY. THEY ARE NOT TO BE DUPLICATED OR USED IN PART OR WHOLE FOR ANY OTHER PURPOSE, PROJECT, LOCATION OR OWNER WITHOUT THE EXPRESS WRITTEN CONSENT OF ANGUS McDONALD/GARY SHARPE & ASSOCIATES, INC.

THE WORD "CERTIFY", AS USED IS UNDERSTOOD TO BE AN EXPRESSION OF PROFESSIONAL OPINION BY THE ENGINEER OR SURVEYOR. IT IS A DECLARATORY STATEMENT WHICH IS BASED ON HIS BEST KNOWLEDGE, INFORMATION AND BELIEF. AS SUCH IT CONSTITUTES NEITHER A GUARANTEE NOR WARRANTY, EXPRESSED OR IMPLIED, OF ANY INFORMATION CONTAINED HEREON. NO CERTIFICATION IS EXPRESSED OR IMPLIED ON ANY ORIGINAL OR ANY DUPLICATE OF THIS PLAN UNLESS IT BEARS AN ORIGINAL STAMP OR SEAL AND ORIGINAL SIGNATURE OF THE INDIVIDUAL WHOSE REGISTRATION NUMBER APPEARS HEREON.

CERTIFICATION NOTES:

1. THIS SURVEY PLAN HAS BEEN PREPARED PURSUANT TO THE REGULATIONS OF CONNECTICUT STATE AGENCIES SECTION 20-300b-1 THROUGH 20-300b-20 AND THE "STANDARDS FOR SURVEYS AND MAPS IN THE STATE OF CONNECTICUT" AS ADOPTED BY THE CONNECTICUT ASSOCIATION OF LAND SURVEYORS, INC. ON SEPTEMBER 26, 1996.

A. TYPE OF SURVEY: IMPROVEMENT LOCATION SURVEY
B. BOUNDARY DETERMINATION: RESURVEY
C. THIS SURVEY CONFORMS TO THE STANDARDS AND ACCURACY OF CLASS A-2 & T-2.

ANGUS L. McDONALD JR.
CONN. L.S. #70173

TO MY KNOWLEDGE AND BELIEF THIS MAP IS SUBSTANTIALLY CORRECT AS NOTED HEREON.

LAND & MARINE
SURVEYING
ENGINEERING
PLANNING

ANGUS McDONALD
GARY SHARPE
& ASSOCIATES, INC.
SINCE 1966

P.O. BOX 808, 245 BOSTON POST ROAD
OLD SAYBROOK, CONNECTICUT 06475
TEL. (860) 388-4671 FAX (860) 388-2962

TRUCK ACCESS DEMONSTRATION PLAN
PREPARED FOR
BLUSKY STREET
175-5 ELM STREET
ELM STREET INDUSTRIAL PARK
OLD SAYBROOK, CONNECTICUT

DATE: MARCH 13, 2024 SCALE: 1"=40'
DR'N MCM CK'D APP'D
SHEET 1 of 1 JOB NO. 246708
REVISIONS: 4-17-24 - CLIENT COMMENTS ADDRESSED

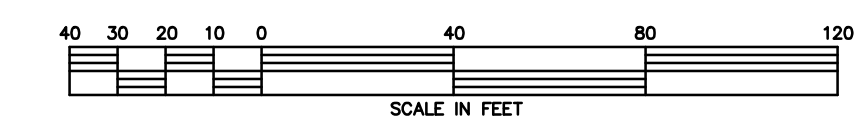

"OPTION 1"